

LEATHER GOODS, ACCESSORIES & JEWELLERY DESIGNER
JULIEBERANGEREMARE.WIX.COM/PORTFOLIO

Julie Maréchal

julieberangere.marechal@gmail.com

+33 (0)6 88 58 99 78

PERSONAL PROJECT

Modern explorers

—
WINTER 2022 - 2023 IS ONE OF THE HOTTEST
EVER RECORDED IN EUROPE.
PAUL NICKLEN'S WORK HIGHLIGHTS THE NEED
FOR DIALOGUE ON HOW CLIMATE CHANGE
AFFECTS THE WORLD AND WHAT CAN BE DONE
TO PROTECT THE EARTH.

—
STRIATIONS-OF-TIME - PAUL NICKLEN
OBBERGOMS - GRIESSEE - MARTIN ADAMS

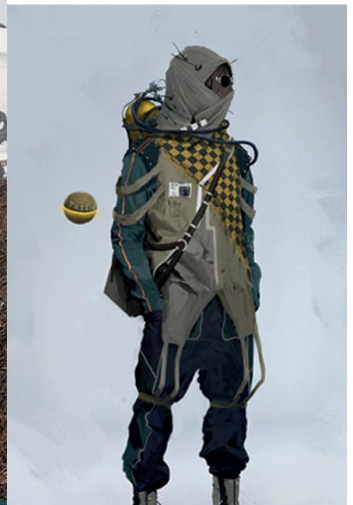

AS BOTH CONSUMERS AND DESIGNERS SHIFT THEIR FOCUS AND SOURCE OF INSPIRATION TOWARDS NATURE PRESERVATION AND ECOSYSTEMS, ONE MAY ASK WHAT TYPE OF PRODUCTS COULD FIT WITH OUR MODERN ACTIVE LIFESTYLES. BEYOND THE ESSENTIAL USE OF SUSTAINABLE AND UPCYCLED MATERIALS THROUGHOUT THE PRODUCT LINE: HOW CAN WE RE-INTERPRET NATURE EXPLORATION VISUAL CODES TO DESIGN LONG-LASTING PRODUCTS WITH SIMPLE AND MODERN FUNCTIONS?

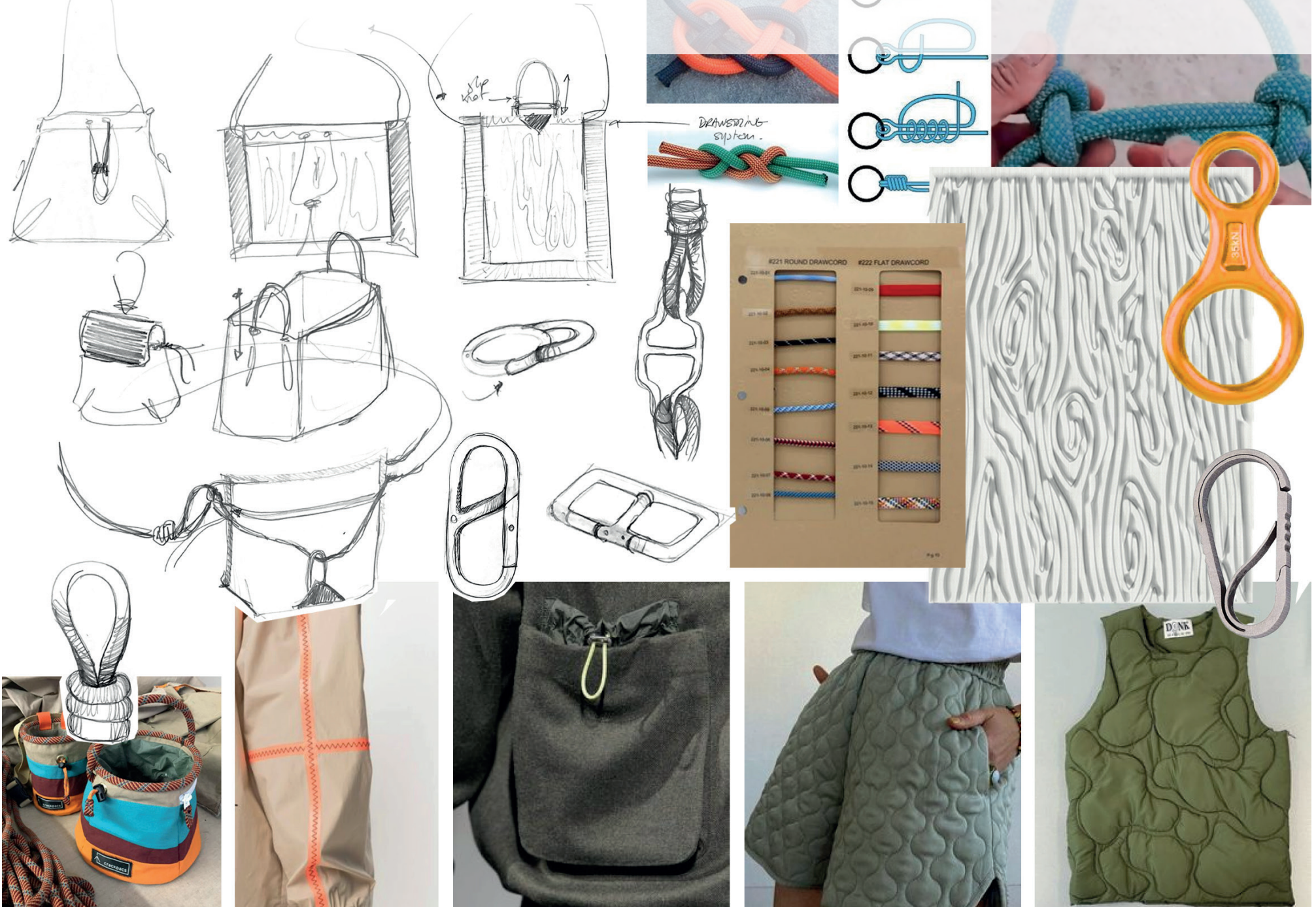

REFLECTIVE
TRIANGLE

DOUBLE SNAP HOOK

QUILTED UPCYCLED
RIPSTOP - PATTERN
INSPIRED FROM THE
ICECAPS



ROPES MADE OF RECYCLED
THREADS

SEALED SEAMS
TO ENSURE
DURABILITY

COLLECTION MADE OF
UPCYCLED EXPEDITION
TENTS FABRICS



CHAOS

Tech and travel accessories .

—

RANGE OF TECH ACCESSORIES. LAPTOP COVER AND CHARGERS STICKERS DECLINED IN EVERY CHAOS LEATHER COLOR SPECTRUM.

—

JAN19 - CORE COLLECTION



**CUSTOMISABLE LAPTOP
COVERS 13' & 15'
AND CHARGER STICKERS
(EU, US, UK)**

NO ONE WILL EVER WALK AWAY WITH YOUR CHARGERS AGAIN! THE CHAOS PERSONALISED TECH COLLECTION IS MADE FROM HARDWEARING GRAINY LEATHER. THE STICKERS ADHERE DIRECTLY THE SURFACE OF YOUR PLUGS. TO COMPLETE THE TRAVEL SET DESIGN OF AN 13' & 15' CUSTOMISED LEATHER NEOPRENE PADDED LAPTOP COVER.



CHAOS

Small leather goods .

—

CARD HOLDER AND TRAVEL POCLETTE.
DECLINED IN EVERY CHAOS LEATHER COLOR
SPECTRUM.

—

JAN19 - CORE COLLECTION



CUSTOMISABLE POCLETTE

DESIGNED TO BE THE PERFECT SIZE FOR DAY TO NIGHT ESSENTIALS, FOR IPAD OR IPAD MINI OR THE IDEAL PLACE TO KEEP ALL OF ESSENTIALS IN ONE PLACE!!

THE POUCH INCLUDES A DISCRETE GENEROUS FRONT POCKET FOR YOUR MOST USED ITEMS, A SMALL GOLD LOOP ON THE SIDE THAT ALLOW YOU TO ATTACH ADDITIONAL CHAOS ACCESSORIES.

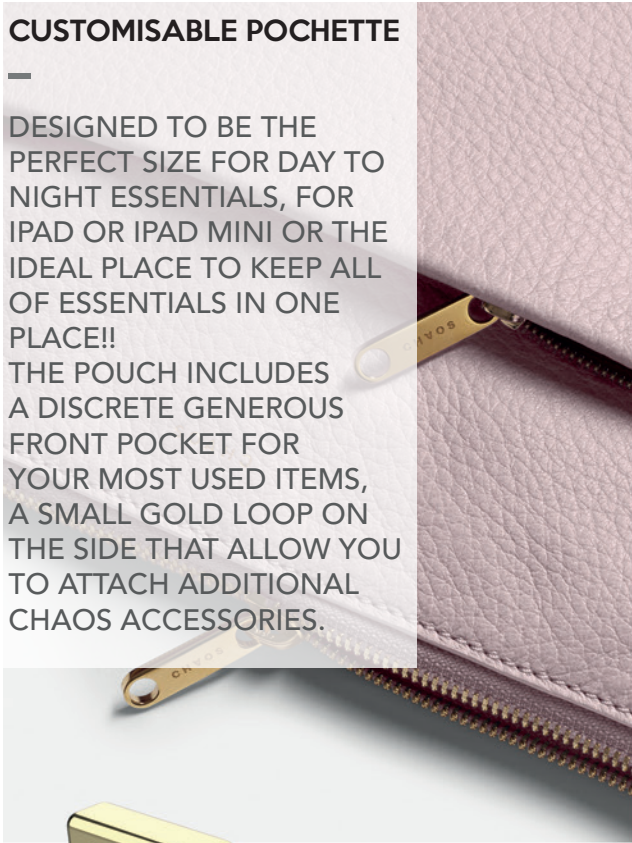

CHVOS

Concertina collection

—

BAG AND CARD HOLDER MADE OUT PATENT
CAMEL LEATHER MAGNIFYING THE
CUSTOM MADE CHAIN AND HARWARE.

—

SS19



CONCERTINA BAG - CARD HOLDER

THE CHAOS CARAMEL PATENT CONCERTINA BAG AND CARD HOLDER ARE DESIGNED TO FIT THE EVERYDAY ESSENTIALS. WITH EASY TO ACCESS COMPARTMENTS KEEPING EVERYTHING ORGANISED AND SIMPLE TO FIND. THE LEATHER STRAP WITH ELEGANT CUSTOM MADE GOLD CHAIN FOR THE BAG ALLOWS IT TO BE WORN CROSS BODY OR CAN BE REMOVED AND TURNS THE BAG INTO AN EVENING CLUTCH. THE CARD HOLDER WITH THE CHAOS CARABINER FEATURE ALLOWS TO HANG IT WHEREVER YOU WANT TO ADD A TOUCH OF ORIGINALITY.

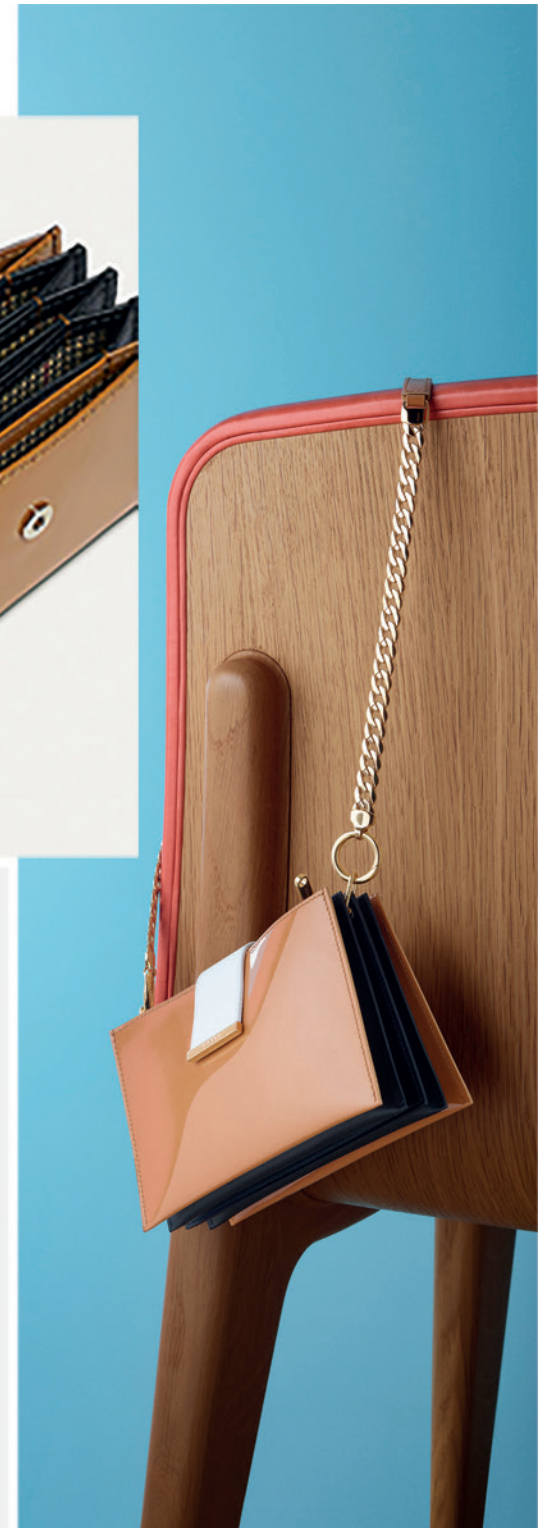

SKETCHES PHASE

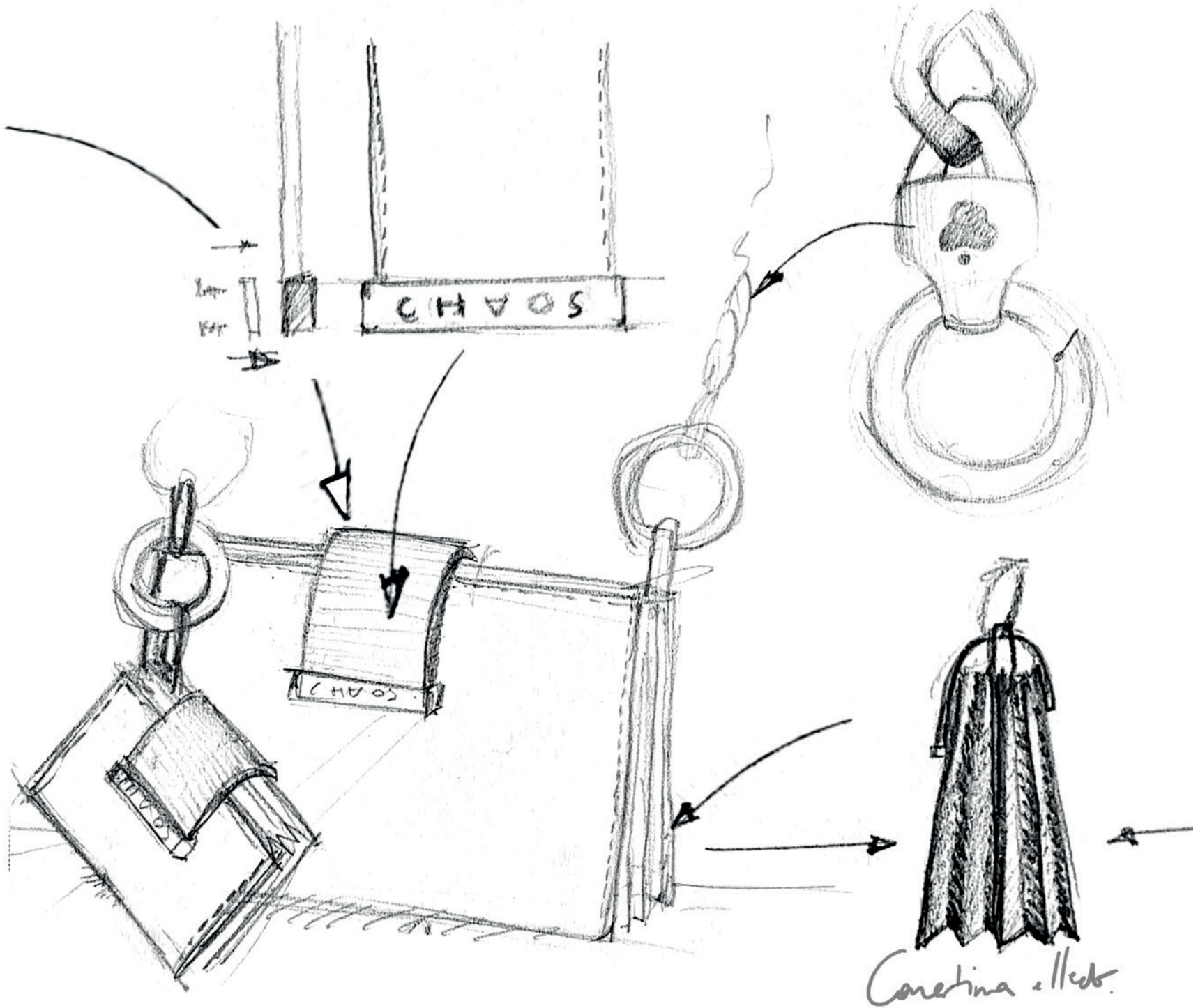

CHVOS

Teddy collection

—

TEDDY FEEL SHEARLING COLLECTION
INCLUDING, PHONE CASES, WRIST STRAP,
POUCH AND LANYARD CHARM. A PERFECT
MATERIAL TO JUMP INTO AUTUMN SEASON

—

PREAW19 / AW19



TEDDY POUCH - PASSPORT COVER - PHONE CASE - WRIST STRAP - GOLD BAR CHARM

A WARM AND COMFY MATERIAL TO ACCESSORIZE OUTFITS AND JUMP INTO AUTUMN. THE MATERIAL IS MAGNIFIED WITH TOUCHES OF GOLD AND CLASSIC COLORS.

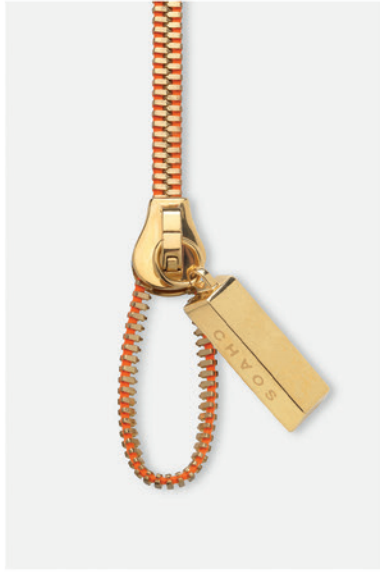

CHVOS

Canvas collection

—

TRIO OF SMALL LEATHER GOODS MADE OUT
OLIVE COATED CANVAS TO ADD A SPRINGY
TOUCH TO YOUR ACCESSORIES - PHONE
CASE WITH INTEGRATED CARD POCKET -
CARD HOLDER - PASSPORT COVER

—

SS19



SKETCHES & MOCK UP PHASE

THE DESIGN WAS MAINLY FOCUSED ON THE HARDWARE PART AND HOW TO INTEGRATE IT NICELY ON THE PRODUCT. THE FITTING (WITH THE CARD AND ON THE PHONE SHELL ITSELF) WAS ALSO AN IMPORTANT FEATURE IN TERMS OF DEVELOPMENT AND DESIGN.

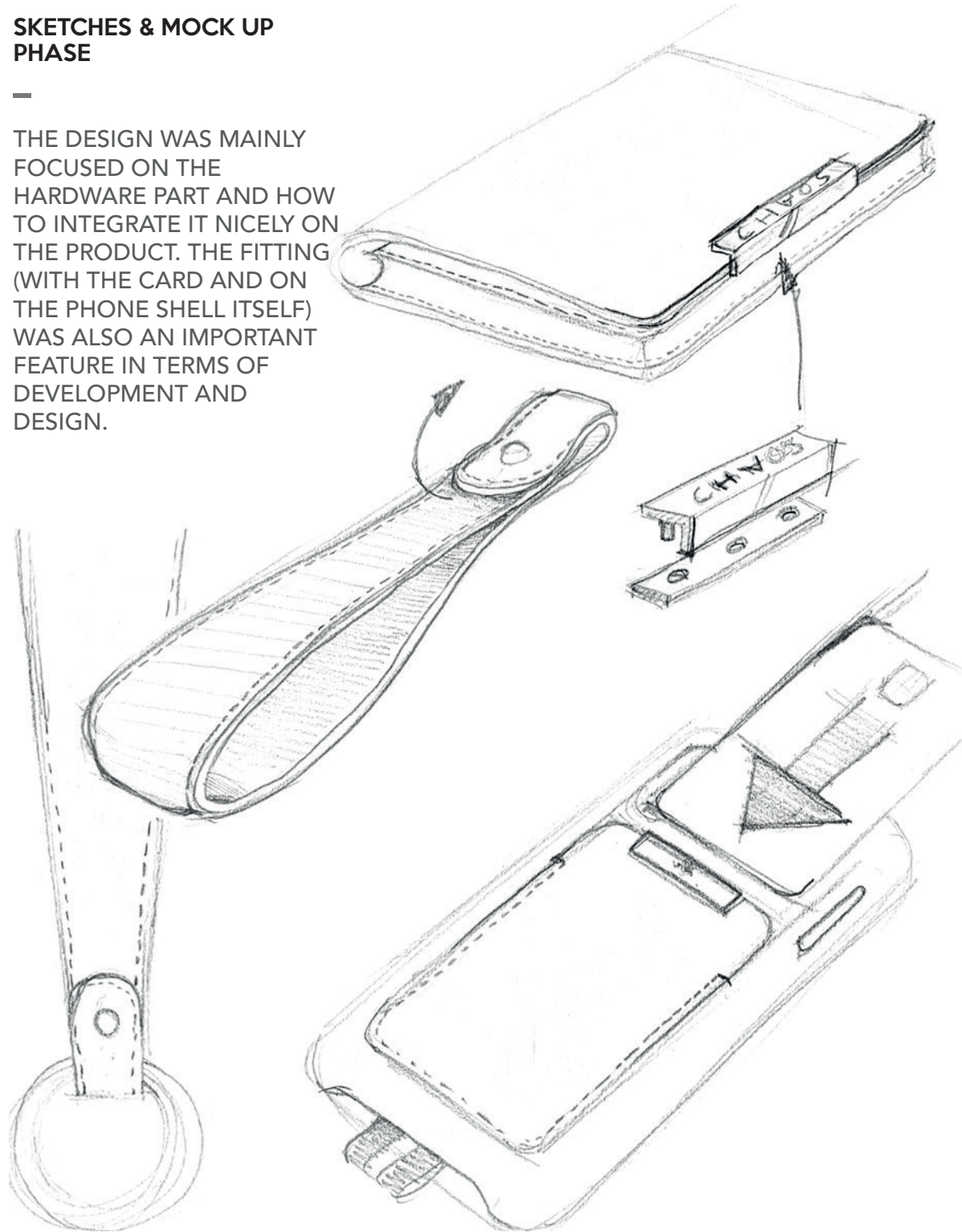

CHVOS

Valentine python hearts

—

HEART QUILTING RED PYTHON
EMBELLISHING A TRIO OF POUCHES.

—

VALENTINE CAPSULE



CHAOS

Expendable tote

—

THE CHAOS LEATHER TOTE IS THE PERFECT EVERYDAY BAG. THANKS TWO GOLD ZIPS ON THE SIDES IT CAN BE WORN FLAT & SLIMLINE OR CAN BE UNZIPPED FOR EXTRA DEPTH

—

DEC19



LEATHER EXTENDABLE TOTE BAG.

DESIGN FOCUS ON THE WAY TO MAKE THE EXTENDABLE FUNCTION PRACTICAL, REFINED AND DISCREET WITH KEEPING CHAOS DNA FEATURES (THE GOLD HARDWARE AND THE ZIPS). WORK AROUND THE HANDLES SHAPE IN ORDER TO HAVE THEM RECOGNISABLE ON THE MINIMAL RECTANGULAR BODY SHAPE.

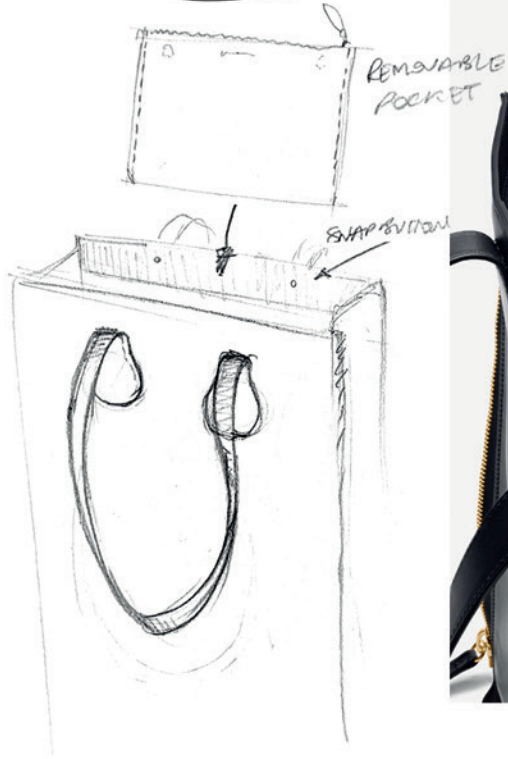
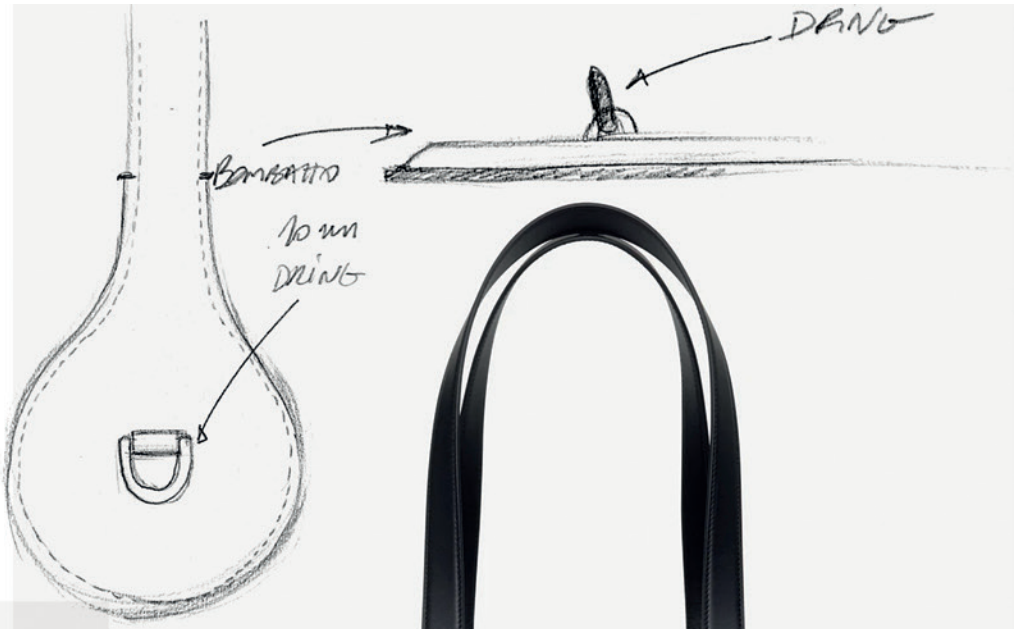

CHVOS

Gingham collection

—
EXPANDABLE TOTE BAG MADE FROM
SHINY COATED BLACK AND WHITE COTTON
GINGHAM WITH SUPPLE LEATHER SHOULDER
STRAPS. MATCHING GINGHAM POUCH

—
SS19



CUSTOMIZABLE EXPANDABLE TOTE - POUCH

—

FEATURES:
EXPANDABLE GUSSETS.
CONTRAST NAVY GINGHAM
CUSTOMIZABLE FRONT
POCKET ,
SOFT DURABLE LEATHER
SHOULDER STRAPS AND
ZIP PULLERS, AN INTERNAL
REMOVABLE ZIP POUCH FOR
THE VALUABLES.
A GOLD LOOP ON THE
FRONT FOR STYLING WITH
CHAOS CHARMS.

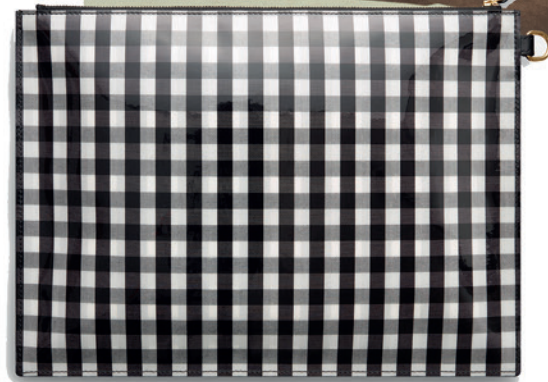

SKETCHES & MOCK UP PHASE

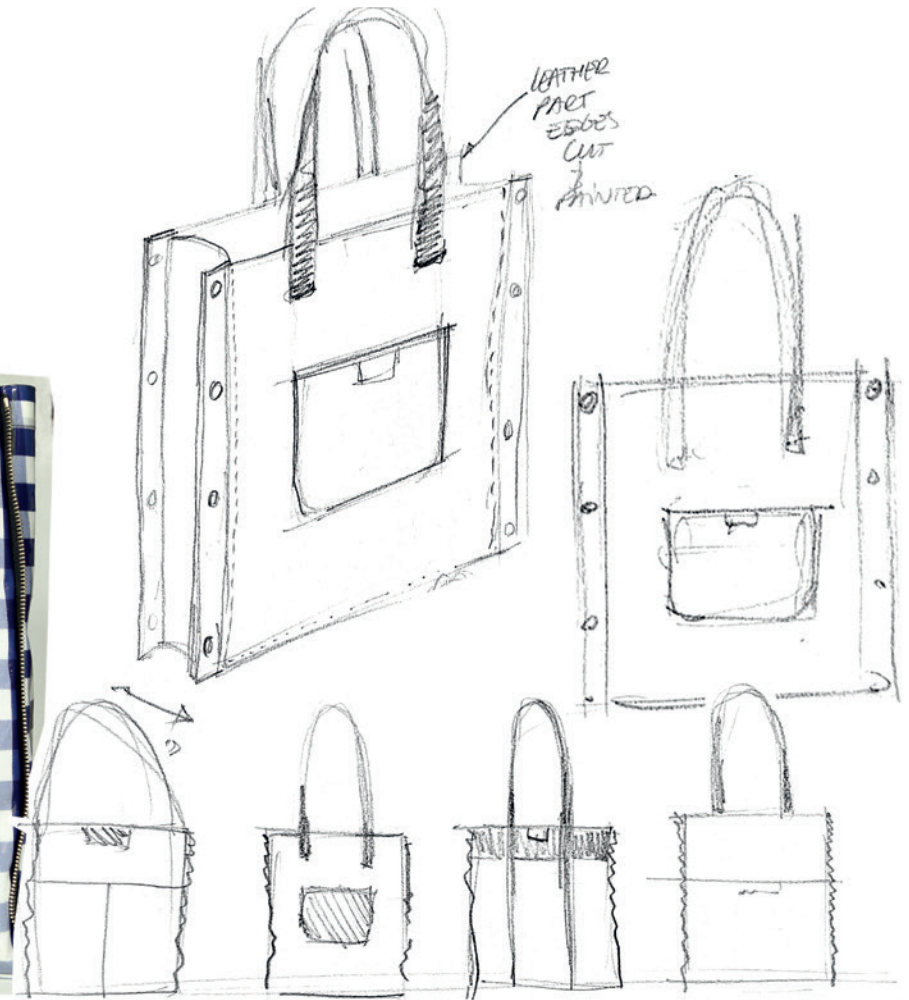

DATE : 7 - 02 -19	ITEM : SLIP CASE PHONE BAG - NAVY GINGHAM	DESIGNER : JULIE
Units : mm		
Material 1 : SMALL NAVY LAMINATED GINGHAM	Living pocket : MORE LIVING	Description : Vertical mini bag, for multi phone sizes - IPHONE XS MAX - GALAXY S9 - GALAXY NOTE 9 - GOOGLE PIXEL 3 XL - HUAWEI MATE 20 PRO
Material 2 : NAPPA LEATHER - ART BONGONOVO CONCENA STELLA		PLEASE MAKE SURE THAT THE HANDFEEL IS LESS CARDBOARDY, AS THE SAMPLE GIVEN.
Hardware : - Snap top and base x1 - Paper grommet gold - Brass chain - Gold chain 2/2	Finishes : - Edges cut and painted	

PLEASE ADVISE REGARDING THE EDGES FINISHES - we want them as sleek / neat as possible

DATE : 14 - 06 -19	ITEM : Zip Pouch - Gingham - v3	DESIGNER : JULIE
Units : mm		
Material 1 : BIG BLACK LAMINATED GINGHAM	Lining : as the samples made - Big Black non laminated gingham	Zip : - 5 lines / 15 black tape gold teeth
Material 2 : SMALL BLACK LAMINATED GINGHAM	Hardware : Gold pull in 10 100 Standard Design	Description : - Covered pouch - recycled
Material 3 : SMALL NAVY LAMINATED GINGHAM	Finishes : - Canvas - 2 edges cut and painted - 2/2 canvas - Edges cut and painted	

Zip pullers / interior lining : ART BONGONOVO CONCENA STELLA

NEW DIMENSIONS - NEW COLORWAYS

CHVOS

Charm hand hug phone case

CUSTOMIZABLE IPHONE CASE WITH GOLD CHARMS SLID ONTO A COMFY ADJUSTABLE HAND STRAP.

PREAW17 / AW17



IPHONE CUSTOMIZABLE HANDHUG

THE CHAOS HAND HUG IS NOW AVAILABLE WITH YOUR CUSTOMISED INITIALS IN THE FORM OF OUR GOLD PHONE JEWELLERY CHARMS WHICH SLOT ONTO YOUR HAND HUG TO GIVE YOU PERSONALISATION WHENEVER YOU LIKE.

SLIP YOUR HAND UNDER THE LIGHT STRAP TO HOLD YOUR PHONE COMFORTABLY TO READ, LIVE STREAM WITH A STEADY HAND OR SELFIE WITH EASE!

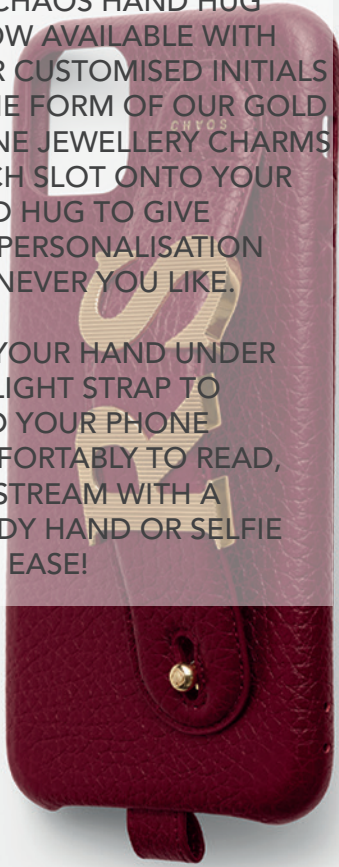

SOPHIE HULME

Bow bag

—
REINTERPRETATION OF THE ICONIC SOPHIE HULME'S SADDLE BAG, THE BARNSBURY. DESIGN FOCUS AROUND THE LEATHERCRAFT TECHNIQUES

—
RESORT 18





SOPHIE HULME

The swing

—
A BUCKET-STYLE BAG. THE SWING IS THE COMBINAISON BETWEEN; AN EVERY DAY BAG, ALLOWING TO CARRY ALL THE ESSENTIALS, AND A STYLISH AND REFINED LOOK WHICH WILL MAKE A PERFECT FINAL TOUCH TO AN OUTFIT.

—
SS18



SWING BAG IN 3 DIFFERENT SIZES. LARGE, MEDIUM, NANO

—
A BUCKET-STYLE BAG, THE SWING IS CRAFTED TO A MINIMAL SILHOUETTE WITH A CIRCULAR BASE AND TWO SIDE PANELS. THE BROAD SHOULDER STRAP IS SECURED VIA OVER-SIZED RIVETS IN THE SIGNATURE POLISHED GOLD-PLATED BRASS, OR FASTEN THE DETACHABLE, ADJUSTABLE STRAP TO CARRY CROSSBODY. THE CLOSURE IS A SIMPLE POPPER FASTENING AND THE INTERIOR INCLUDES A SIMPLE SLIP POCKET FOR VALUABLES



SOPHIE HULME

Bolt

—
MODERN AND MINIMAL, CLEAN AND CONTEMPORARY - THIS SHOULDER BAG MEETS ALL DAY - TO-DAY DEMANDS. THE STRAP CAN BE ADJUSTED, AND THE HANDLE REMOVED THANKS TO THOSE CHUNKY GOLD-TONED BOLTS.

—
SS18



SMALL AND MEDIUM SIZE

CLEAN LINES AND SOFTEST LEATHER, THE BOLT ENCAPSULATES SOPHIE HULME'S FUNCTIONAL PHILOSOPHY, AVAILABLE IN TWO SILHOUETTES AND SEVERAL COLOURWAYS. THIS VERSATILE STYLE CAN BE CARRIED MULTIPLE WAYS - A TOP HANDLE AND SHOULDER STRAP, BOTH REMOVABLE AND FULLY ADJUSTABLE VIA POLISHED GOLD-PLATED CLIPS. THESE SPECIFIC PARTS HAVE BEEN INSPIRED FROM MILITARY BELT ATTACHMENTS. A ZIP CLOSURE ENSURES CONTENTS ARE SAFE.

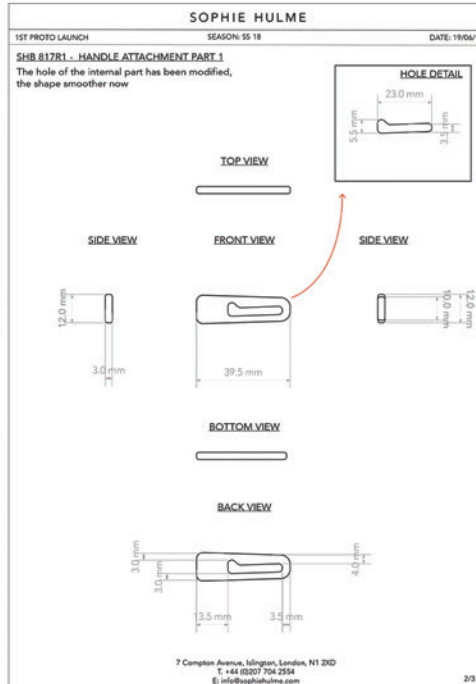
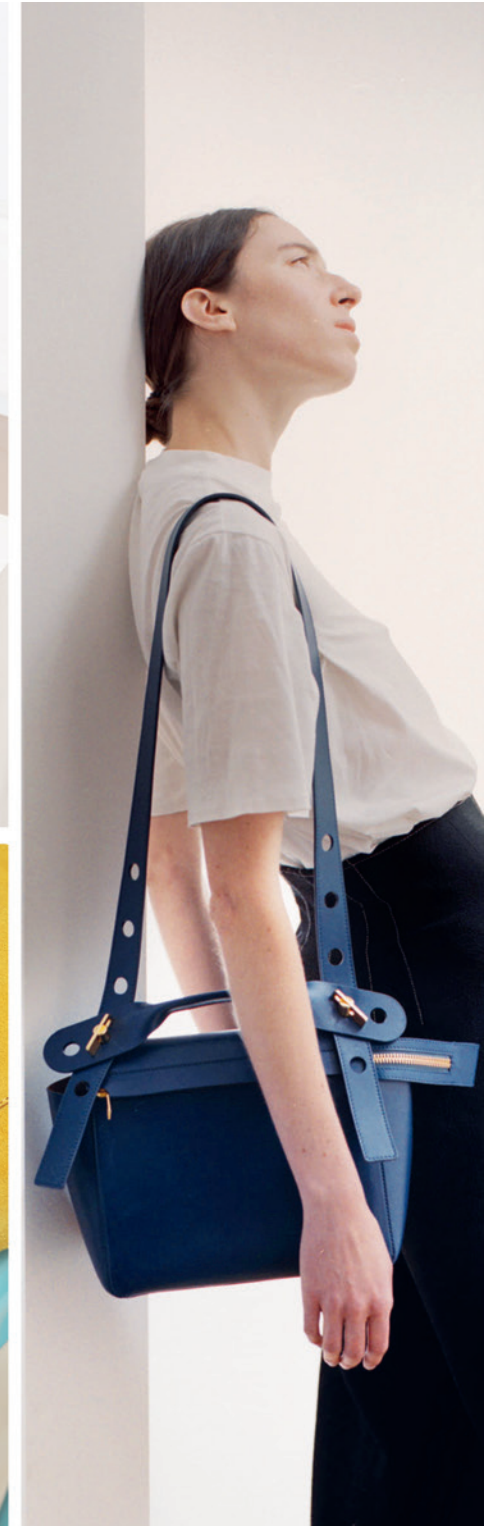

SOPHIE HULME

Spring . stack leather chain

—

BAG AND ACCESSORIES COLLECTION
AROUND THE COCKTAIL STIRRER CHARM
PREVIOUSLY DEVELOPED. THE CHARM IS
NOW A LOCK.

—

SS18



SMALL AND MEDIUM SIZE

THE CLEAN SILHOUETTE IS CRAFTED FROM SOFT SADDLE LEATHER WITH STACK LEATHER CHAIN LINK HANDLE, REINTERPRETING THE SHOE SOLE LEATHER CRAFT TECHNIQUE "CUOIO". THE SHOULDER STRAP CAN BE DETACHABLE. THE GOLD-PLATED SLEEK BRASS FASTENING REVEALS A CONTRASTED SUEDE LINING. LET THE VIVID HUE TAKE CENTER STAGE AGAINST TONAL SEPARATES.



SKETCHES & MOCK UP PHASE



SOPHIE HULME

COMMENTS: SEASON: RESORT 18 DATE: 22/06/17

NAME OF BAG: CHAIN SOFT FLAP SMALL

INSTRUCTION: STACKED LEATHER SADDLE / CUOIO

25/06/2017 Please follow this shape of link

most perfect character for your brand...
Rings with PUSTELLA + MOULD

6 links by chain + 2 Drings

shoes heels technique

Stitching on this link thread reference please see p4

Stitching on this link thread reference please see p4

Stitching on this link thread reference please see p4

Stitching on this link thread reference please see p4

7 Compton Avenue, Islington, London, N1 2XD
T: +44 (0)207 704 2554
E: info@sophiehulme.com

FRONT VIEW

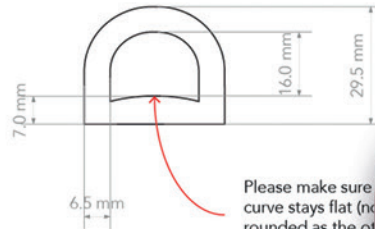

Please make sure curve stays flat (not rounded as the other edges) to ensure bag flap sits properly on it

DE VIEW

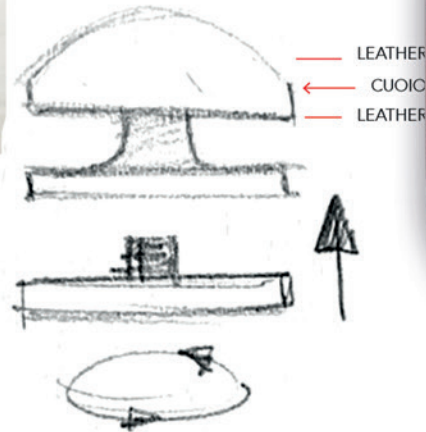

KEYHOLE CLOSURE



SOPHIE HULME

Pinch . pencil case closure

—
THIS COLLECTION GOES BACK TO THE
BRAND ROOTS - CAREFULLY SOURCED
MATERIALS, INVENTIVE DETAILS, MINIMAL
DESIGN. THE PIECES ARE CREATED TO BE
CARRIED FOR LIFE.

—
SS18



HOBO & CROSS BODY MODELS

—

THE PINCH COLLECTION ENHANCES CLEAN LINES AND ARCHITECTURAL DESIGN FOR AN EVERYDAY WEAR. THE MATT FINISH SOFTENED SADDLE LEATHER, CRAFTED INTO A STRUCTURED SILHOUETTE PLAYS WITH THE POLISHED GOLD-PLATED FASTENING, WHICH A PENCIL IS CONCEALED WITHIN. MINIMAL DETAILS FOR A MAXIMUM FUNCTION.



PREAW17 /AW17

NEW COLLECTION
DESIGNED AROUND THE
EVENING PARTY THEME

Party Inspiration



Chatelaine
Charms collection



Iridescent Pink Glitter



Black



Klein Blue
pantone 2147C



Fire Brick
pantone 188C

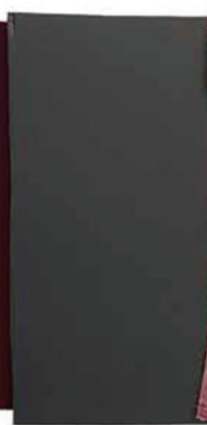

Charcoal
pantone 425C



Pink Snake



Tan Velvet

SOPHIE HULME

Cocktail stirrer bag . small

—

BAG AND ACCESSORIES COLLECTION
AROUND THE COCKTAIL STIRRER CHARM
PREVIOUSLY DEVELOPED. THE CHARM IS
NOW A LOCK.

—

PREAW17 / AW17



COCKTAIL STIRRER BAG SMALL

THE FOCAL POINT OF THE MINIMAL SILHOUETTE IS THE LOCK MECHANISM - A BRASS COCKTAIL STIRRER WHICH LOOPS THROUGH A CATCH ON THE FRONT OF THE BAG.

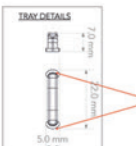
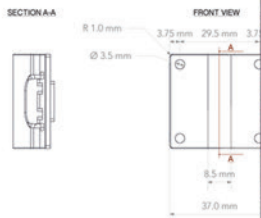
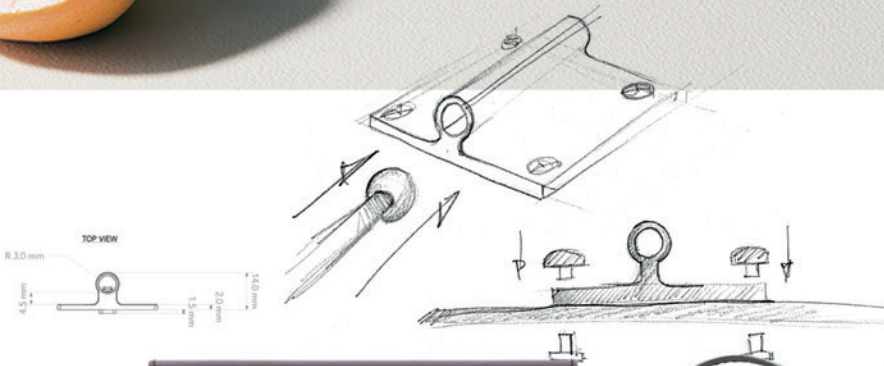
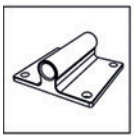

COCKTAIL STIRRER BAG
LARGE



SOPHIE HULME

Straw lockbag

—
THE SOPHIE HULME STRAW IS MORE THAN AN ORNAMENTAL ODE TO THIS LASTING DESIGN. THE DEVICE IS THE LOCKING MECHANISM FOR A SHOULDER-COME-HANDBAG IN THE CATCH COLLECTION LINE UP

—
PREAW17 / AW17



STRAW LOCK BAG

MINIMAL DETAILS - STRUCTURED SADDLE LEATHER, SQUARED SILHOUETTE - ARE PUNCTUATED BY THE POLISHED, GOLD-PLATED FASTENING. THE STRAW BAG IS ALL-IN-ONE. FOR HANDS-FREE HOLDING, THE SAME STRAP CAN BE SWITCHED TO SHOULDER LENGTH. OR, ON OCCASIONS THAT DEMAND STRAPLESS STYLE, UNBUCKLE ALTOGETHER AND CARRY AS A CLUTCH.



SKETCHES & MOCK UP PHASE

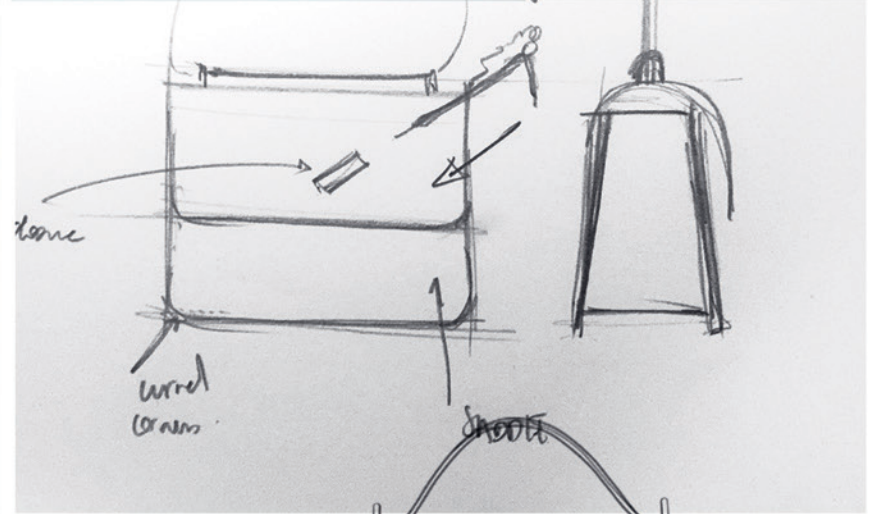
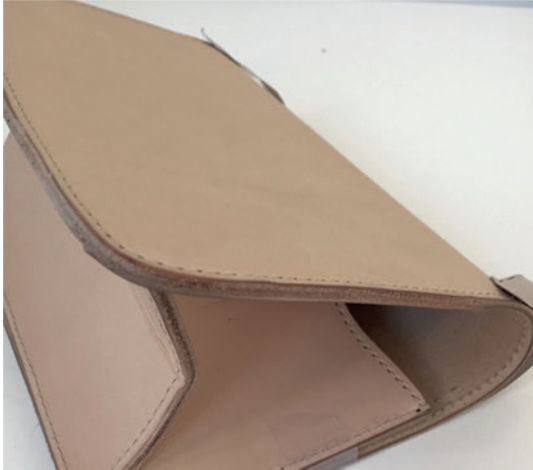

SOPHIE HULME
 SEASON: PRE AW17 DATE: 09/12/16
 SHB742R1A LOCK PLATE FOR CHARMS CLOSURE WITH MECHANISM (COCKTAIL STIRRER).

TOP VIEW
 R 3.0 mm
 4.2 mm
 1.5 mm
 20.0 mm
 14.0 mm

SECTION A-A
 R 1.0 mm
 Ø 3.5 mm
 1.5 mm
 4.5 mm
 7.5 mm

FRONT VIEW
 3.75 mm 29.5 mm 3.75 mm
 3.5 mm 27.5 mm 3.5 mm
 6.5 mm
 37.0 mm

SIDE VIEW
 36.0 mm
 1.5 mm
 4.5 mm
 7.5 mm

TECH. DETAILS
 7.0 mm
 2.0 mm
 5.0 mm

This area have to be really smooth and polished to slide easily the stirrer inside the tube

Units : mm
 Scale 1/1

7 Compton Avenue, Islington, London, N1 2XD
 T. +44 (0)207 704 2554
 E. info@sophiehulme.com

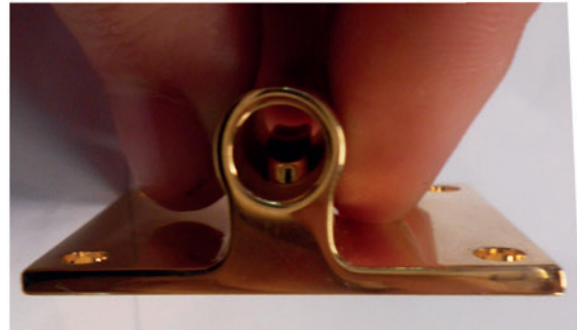

SOPHIE HULME

Charms collection

DESIGN OF A VARIETY OF BRASS CHARMS AROUND THE PARTY THEME.

TRUMPET CASE, TRUE OR LIE DETECTOR, LOVE HEART CANDY CASE, NAME TAG, PARTY POPPER, CANDLE HOLDER / CANDLE CASING.

PREAW17 / AW17



SOPHIE HULME

Whistle clutch

—

AN ELEGANT MEMBER OF THE PARTY COLLECTION, THIS EVENING STYLE COMBINES GLITTERY PERSPEX WITH A POLISHED GOLD-PLATED FRAME. THE ROUNDED RECTANGLE SILHOUETTE HINGES OPEN VIA A LOCKING MECHANISM WHICH CENTRES ON A WHISTLE CHARM

—

PREAW17 / AW17



**PERSPEX AND PONY
DECLINATIONS**

—
FUNCTIONAL WHISTLE
CLOSURE. THE MINI
HINGED CLASPS WITH A
REMOVABLE CHAIN STRAP
CONVERT THE STYLE TO A
SHOULDER BAG.



3D RENDERINGS

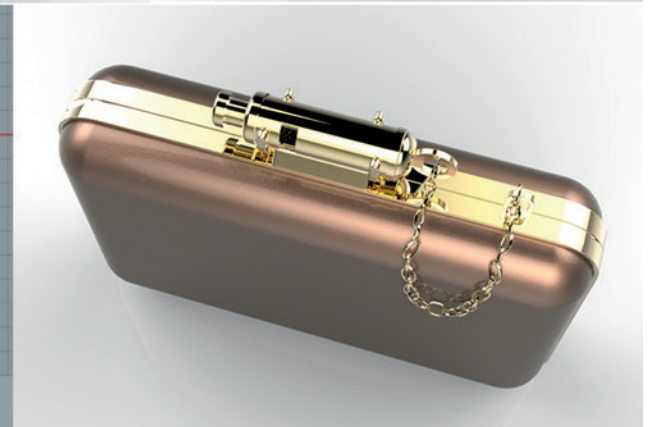
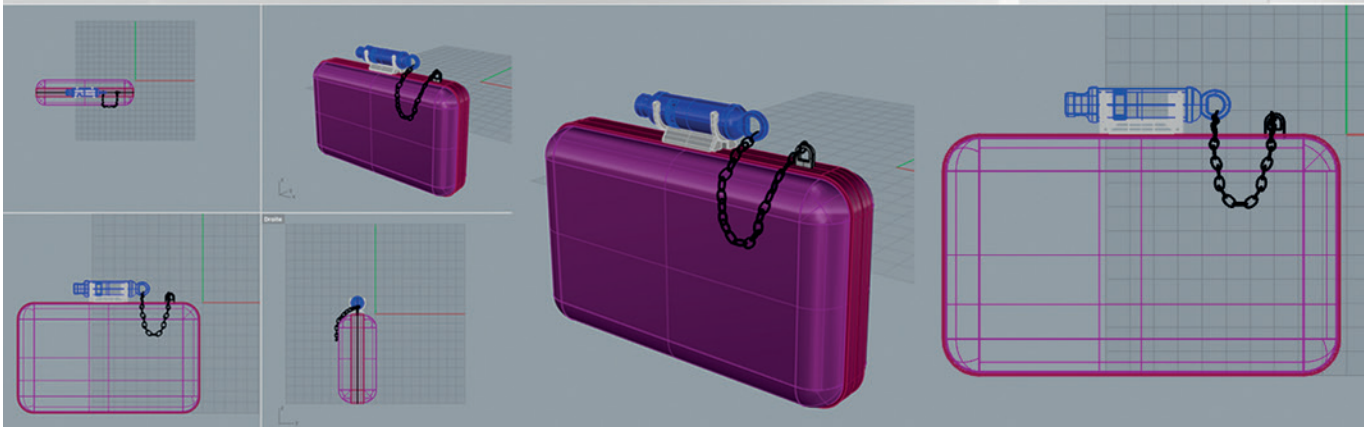

SOPHIE HULME

Whistle case

—
IN LINE WITH THE WHISTLE CLUTCH, THIS BAG WITH A GOLD ROUNDED FRAME IS CLOSED THANKS TO A FUNCTIONAL WHISTLE.
—

PREAW17 / AW17



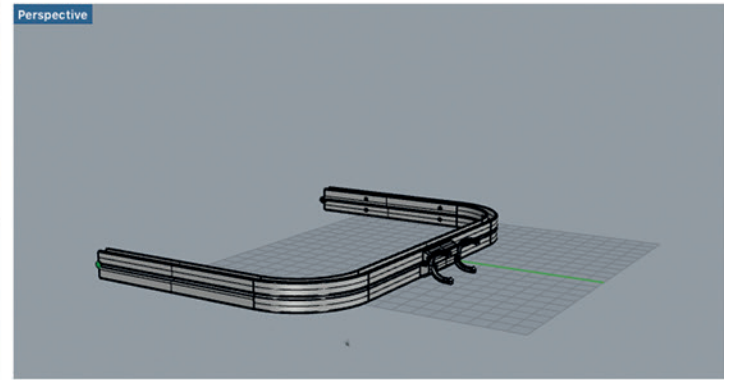
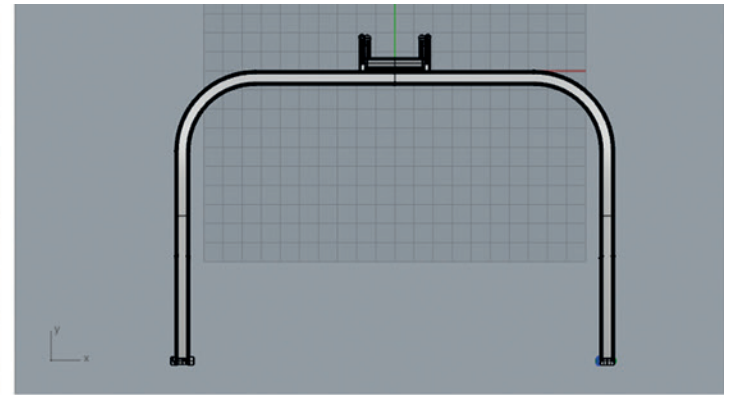

SOPHIE HULME

HARDWARE LAUNCH SEASON AW 17 DATE: 20/12/16

SHB788R WHISTLE CASE FRAME

SECTION A-A Fixing system

The leather is fixed in the "u shape" frame

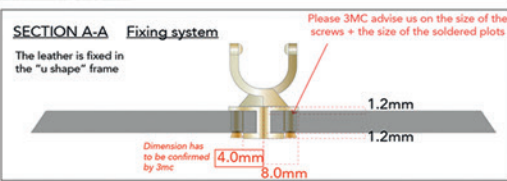

Please 3MC advise us on the size of the screws + the size of the soldered plots

Dimension has to be confirmed by 3mc

PLEASE MAKE SURE THAT THE FRAME HAS SCREWS TO FIX THE LEATHER INSIDE

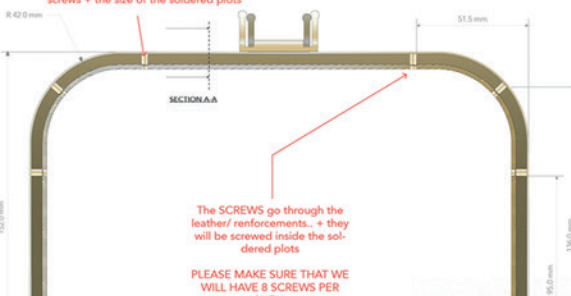

Please 3MC advise us on the size of the screws + the size of the soldered plots

The SCREWS go through the leather/ reinforcements.. + they will be screwed inside the soldered plots

PLEASE MAKE SURE THAT WE WILL HAVE 8 SCREWS PER SHELL

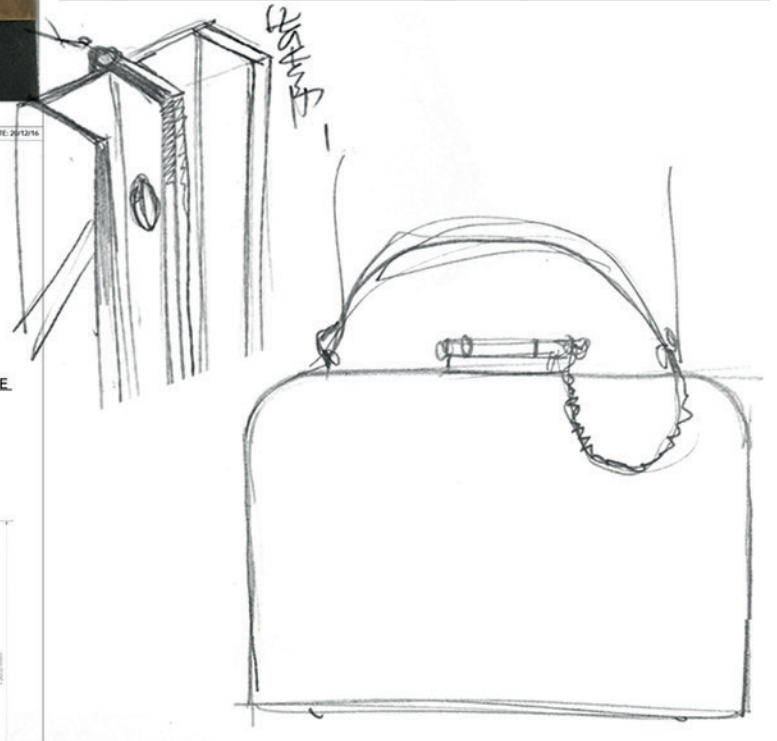

S.T. Dupont
PARIS

Men accessories • Fire head

—
DESIGN OF NEW ICONIC PATTERN.
INSPIRED BY THE FIRE SYMBOL. THE AIM
OF THIS LINE WAS TO PROPOSE A WIDE
RANGE OF PRODUCTS WHICH GATHERED
THE SAME SYMBOL EXPRESSED IN DIFFERENT
WAYS.

—
WINTER 2015

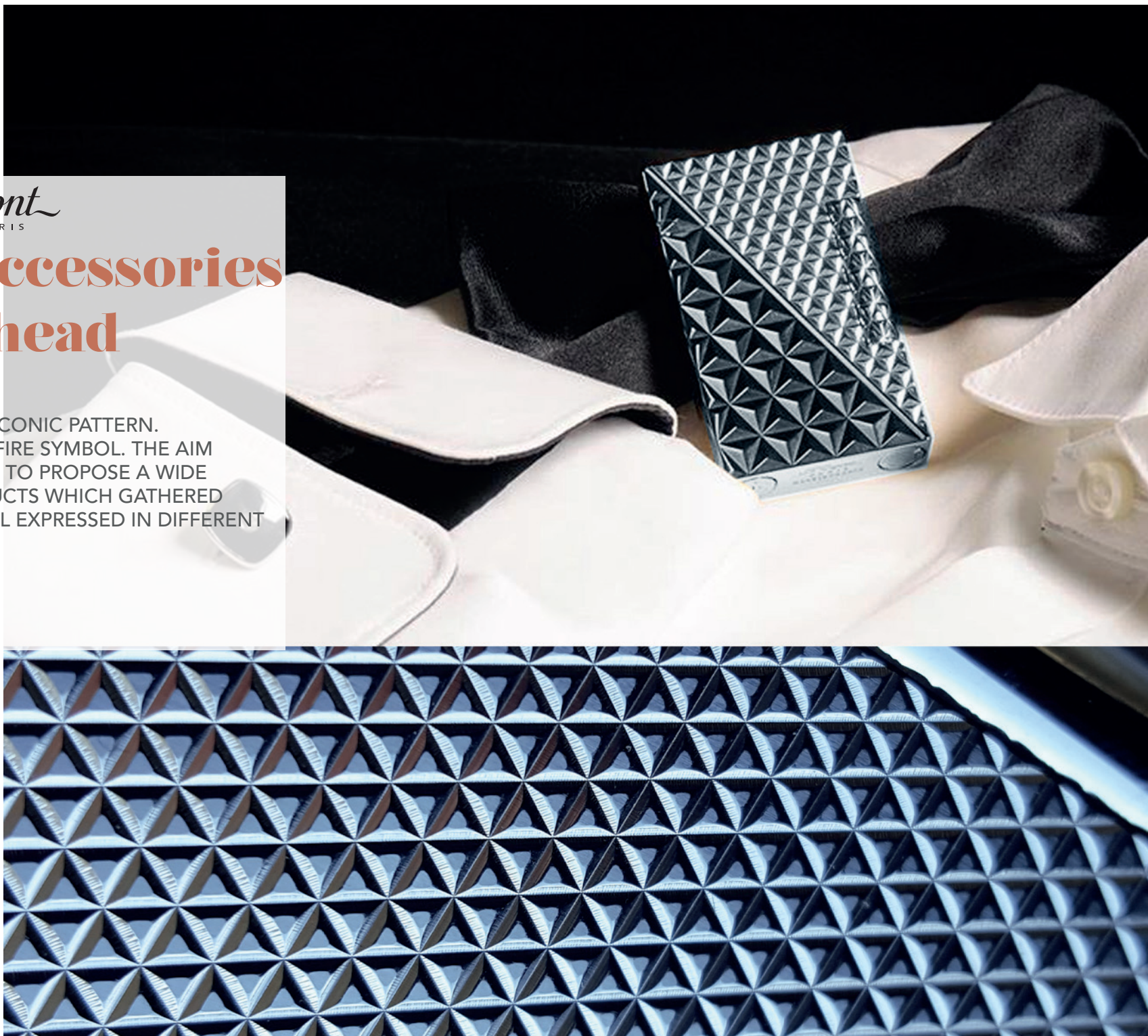

**RANGE OF ACCESSORIES :
BELT BUCKLE AND STRAP,
LIGHTER, PEN, KEYSRING,
WALLETS, CUFFLINKS**

—
COMBINATION BETWEEN
METAL ENGRAVING
TECHNICS AND LEATHER
WORK, ENHANCING THE
VARIOUS FACET OF THE
DIAMOND PATTERN



S.T. Dupont
PARIS

Atelier collection

—

THIS LINE IS A TRIBUTE TO THE FIRST ST DUPONT FORM OF KNOW-HOW : THE ART OF «POPOTÉ». THIS ANCIENT TECHNIQUE INVOLVES PRODUCING A PATINATED EFFECT USING DIFFERENT SHADES OF COLOURS. GIVING RISE TO A COLORFUL COLLECTION OF LEATHERGOODS AND ACCESSORIES.

—

AW16





S.T. Dupont
PARIS

Dline soft

—

LINE OF LARGE AND SMALL LEATHERGOODS DEDICATED TO EASY TRAVELERS. CONTEMPORARY STYLE AND DURABILITY PERFECTLY SUITED TO THE DEMANDS OF A FAST-PACED LIFESTYLE. SOFT, SUPPLE CALF LEATHER IS TREATED WITH THE SIGNATURE DIAMOND TANNING TECHNIQUE TO CREATE A SOFT YET HIGHLY RESILIENT FINISH.

—

OCT14/APR15



SIMPLE & DOUBLE BRIEFCASES, DUFFLEBAG, CROSS BODY LARGE & SMALL, MESSENGER, DOUBLE DOCUMENT HOLDER

—
THE DESIGN OF THIS LINE WAS FOCUSED ON LIGHTNESS, LEATHER TOUGHNESS, COMFORT, ERGONOMICS WITH AN EXTRA ATTENTION TO FUNCTIONALITY.



RUGSACK, TOTE, SIMPLE
AND DOCUMENT HOLDER,
CROSS BODY



GRAINED
CALF





SOFT CALF



GRAINED SOFT CALF